



CASE
CONSTRUCTION

E-SERIES CRAWLER EXCAVATORS



CX130E | CX160E | CX180E

HERITAGE

A TRADITION OF INDUSTRY FIRSTS



1842

CASE is founded.

1869

The first CASE portable steam engine - road construction is born.

1957

The first factory-integrated loader/backhoe in the world: a CASE industry first.

1969

CASE begins skid steer loader production.

1977

CASE acquires Poclain, a French brand leader in the excavators market.

1992

Sumitomo becomes supplier to CASE Corporation distributing excavators ranging from 7 to 80 tons.

1998

Global Alliance signed between CASE Corporation and Sumitomo.

2001

CASE introduces the first of its CX excavators, powerful new “thinking machines” designed to enhance productivity through onboard intelligence features.

2007

CX210B is awarded the «Good Design Award» by the design Academy of Japan.

2008

CX210B wins the 18th «Energy Conservation Award» from the Agency for Natural Resources and Energy of the Japanese Ministry of Economy.

2011

CASE becomes the first construction equipment manufacturer to offer both selective catalytic reduction and cooled exhaust gas recirculation as solutions to meet stringent emissions standards.

2015

CASE launches the new “D-Series” Tier 4 final / EU Stage IV Crawler Excavators.

2018

Stage V production for models CX350D and above, followed by Short Radius models.

2021

CASE introduces the first models of Stage V E-Series Crawler Excavators, featuring new FPT engine, new monitor, enhanced hydraulics and improved connected services.

CRAWLER EXCAVATORS

E-ENHANCED GENERATION

ENHANCED QUALITY AND RELIABILITY

Stronger than ever, built to last

- + The reinforced clamp improves the pipe holding force on the boom.
- + The shape and thickness of the inner reinforcement plate increase the boom's durability.
- + The tolerance of the boom and arm cylinder pins has been updated to reduce clatter and play within the bushing.
- + A new stop valve adjustment mechanism has been added for easier piping-valve connection.
- + The more compact assembly of the undercarriage recoil spring on the CX130E, also including the grease cylinder on CX160E / CX180E, facilitates clearing the mud.
- + The CX130E features a reinforced and more durable travel motor, while CX160E / CX180E deliver increased performances in travelling.
- + The upper carrier rollers (on CX160E / CX180E / CX210E / CX250E) have been upgraded for greater durability.

ENHANCED PRECISION AND CONTROLLABILITY

Smooth control, efficient operation – more than ever

The trademark **CASE Intelligent Hydraulic System (CIHS)** is now paired with new work modes and adjustable hydraulic settings to deliver smoother and more efficient operation than the previous generation.



E-SERIES

CRAWLER EXCAVATORS

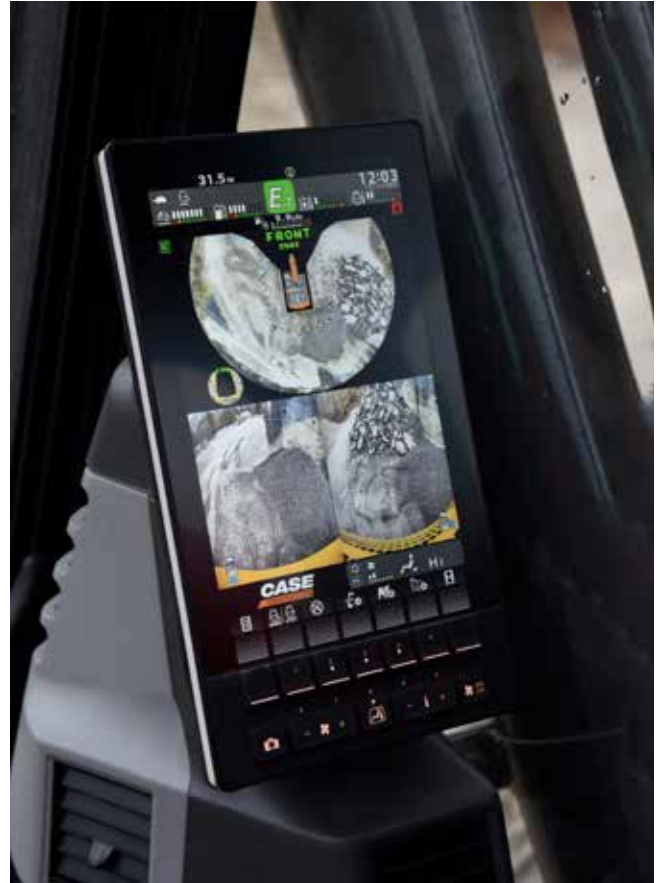

ENHANCED VERSATILITY

A high degree of customization for every task

The new-concept work modes with independent throttle position offer a precise match to the requirements of every task:

SP (Super Power) mode for maximum productivity (as in D-Series) with the throttle set at maximum power.

P (Power) mode replaces H and A mode in D-Series, with throttle settings from 1 to 10.

E (Eco) mode for maximum fuel economy, with throttle settings from 1 to 10.

L (Lifting) mode is optimized for object handling with power boost permanently activated and overload warning system, and throttle settings from 1 to 6.

The choice of available work modes can be locked by the machine owner.

NEW The ground-breaking Eco mode reduces fuel consumption through selective control of engine and pump depending on the movement. It maintains maximum pump torque to deliver high productivity, while minimizing fuel consumption during low effort operations.



The balance of the hydraulic flows can also be customized to suit the operator's preferences:

- + **“Arm In” vs “Boom Up”**
- + **“Arm In” vs “Swing”**

The E-Series takes versatility even further by enabling the operator to select the type of work tool and input the customizable model number on the machine's monitor. When selecting the flow and pressure settings, they can also set the maximum overflow to protect the attachment.



PRODUCTIVITY

WORK SMART, PRODUCE MORE

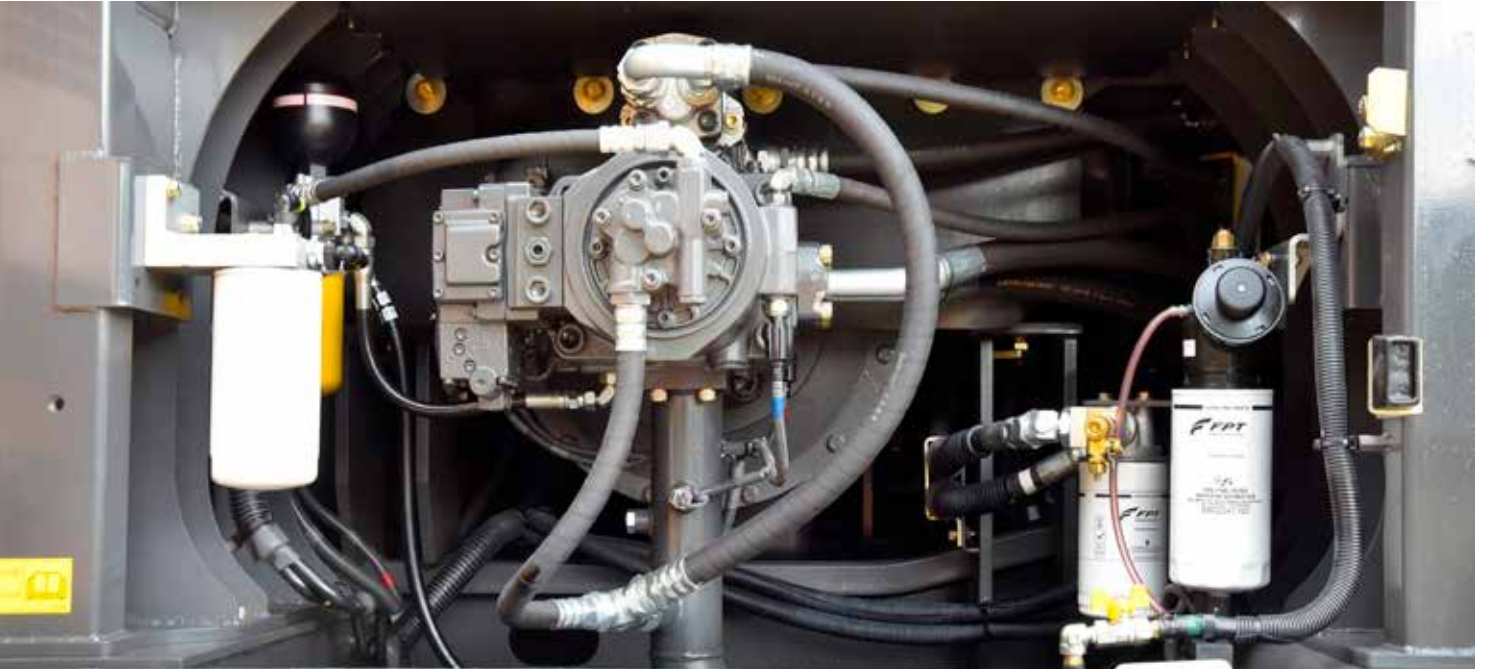

ENHANCED EFFICIENCY

Top performance, high fuel economy

The new-generation E-Series combines the proven energy saving features of the D-Series with new work modes and hydraulic settings to raise the bar on efficiency.

The advanced automatic energy management system inherited from the D-Series consists of six key energy control functionalities:

- + **Pump Torque Control:** prevents drops in engine speed due to overtorque in high load operations while reducing fuel consumption in operations where maximum pump power is not required.
- + **Boom Economy Control:** increases fuel efficiency during boom down and swing movements.
- + **Swing Relief Control:** reduces the initial pump flow while improving control at the start of swing movements to lower fuel consumption.
- + **Spool Stroke Control:** automatically adjusts pressure based on the sensors' feedback, avoiding unnecessary functionality.
- + **Boom Oil Regeneration:** the returning oil from boom down is used to speed up the arm out movement (only from CX210E upward).
- + **Auto Idle / Idle Shutdown:** customizable and manually switchable functions that lower engine rpms after a period of inactivity or shut down the engine after a period of idling.

With all these features, coordinated by the CASE Intelligent Hydraulic System, together with the new FPT engine and improved travel motor for additional mechanical efficiency, the E-Series excavators deliver unprecedented performance and high fuel economy.

CX160E / CX180E hydraulics has been further improved thanks to a 12% increase in the pump flow rate output.



CLEANER POWER

EU Stage V compliant engines



The new FPT NEF engines meet Stage V standards with the innovative HI-eSCR2 solution developed in-house, which only uses a Diesel Oxidation Catalyst and an integrated **maintenance-free** device on the SCR catalyst to achieve this dramatic reduction in emissions.

- + The SCR-on-Filter is “built-for-life” and requires no replacement or mechanical cleaning for its entire guaranteed emission regulation life.
- + The air intake flow is increased by a turbocharger with air-to-air cooling.
- + The multiple injection delivers best-in-class high torque performance at low rpms.
- + **No EGR** valve means 100% fresh air is used for combustion and no extra cooling system is required.

The new Stage V NEF engines can take their low-emission performance even further, as they can operate on **B7 biodiesel** and **HVO** (an even cleaner and more high-quality alternative to biodiesel, with superior performances in cold weathers) and other paraffinic fuels like **GTL** (Gas-to-Liquids), **CTL** (Coal-to-Liquids), **BTL** (Biomass-to-Liquids).

COMFORT RULES

FIRST-CLASS WORK ENVIRONMENT



ENHANCED COMFORT

Ideal working conditions, every day

- + Pressurized cab with improved sealing, wide access space and increased foot space.
- + Ergonomic air-suspended high-back seat with tilt adjustment and optional heater.
- + Console suspended with the seat and optimized control lever positions: the operator maintains their preferred working posture when adjusting the seat's position.
- + Reduced pedal travel and footrest reduce fatigue during operation.
- + Automatic air conditioning controls integrated in the monitor.
- + Air conditioning performance improved with a cooling upgrade and optimal air vents location.
- + Optimized storage capacity with lunch box tray and cool box, smartphone tray, and two large drink holders.
- + Repositioned lower track rollers reduce vibrations for smoother travelling.
- + Quieter cab with 1 dB lower internal noise compared to D-Series on CX210E, and 3 dB lower on CX250E / CX300E.



SAFETY AND MAINTENANCE

WORK SAFELY IN ALL CONDITIONS

SAFER OPERATION AND ACCESSIBILITY

Safety first, inside and outside the cab

- + Reinforced cab structure ROPS and FOPS compliant.
- + Standard FOPS level 2 head protection.
- + Factory fitted front guard OPG level 2; grill guard and front guard OPG level 1 available as DIA kits.
- + Optional factory fitted travel alarm for greater safety on the jobsite around the machine.
- + New auto lever lock safety feature immediately stops machine movement when the operator unintentionally unlocks the gate lock.
- + Seat belt fastened detection.
- + Wide, robust and comfortable steps, and handrail for safe access to the top of the hood.
- + Non-slip plates and top hood cover supported by two gas pistons and secured by two mechanical stops.
- + Wide platform on top of the engine compartment to work safely on the engine box.

SUPERIOR VISIBILITY

Designed for outstanding visibility

Visibility – already outstanding in the D-Series - has been further enhanced:

- + Glazed surface with improved visibility on the right hand side.
- + Bigger monitor (from 7 to 10”) with higher resolution, five configurable buttons and additional menus on the display.
- + Standard rear- and right-hand cameras, and an optional left-hand camera is available for the 270° CASE Maximum View Monitor with revised screen layout.
- + Upgraded cameras for better color balance.
- + Improved front window defrost.
- + New diffusion spray type window washer nozzle ensures better windshield cleaning.
- + Optional LED lights package available for brighter and wider illumination.
- + “Follow me” lights function with selectable off timer.



SAFETY AND MAINTENANCE

WORK SAFELY IN ALL CONDITIONS



EASY MAINTENANCE

"Grounded" and connected services solution

- + New extended service intervals for lower maintenance costs:
 - **Engine oil, fuel & oil filters** extended from 500 to 1,000 hours;
 - **AdBlue supply module filter** was 3,000 hours, it goes up to 4,000 hours;
 - **Travel gear oil** extended from 1,000 to 2,000 hours (on CX160E / CX180E).
- + Extended Maintenance System (EMS) bushings provide 1,000 hour greasing intervals on arm and boom pins and 250 hours on the attachment pin.
- + No EGR reduces complexity in the ATS.
- + SCR-on-Filter auto-cleaning device requires no replacement or mechanical cleaning during guaranteed life span.
- + Fuel nozzle with integrated fuel tank float provides better visibility during refilling.
- + Hydraulic oil tank cap with integrated air breather for tool-less refill.
- + Newly added sampling valve in pump room for easier hydraulic oil sampling.
- + Increased washer tank capacity for fewer washer refills.
- + Grease cylinder compact design for easier mud cleaning around carrier rollers on CX160E / CX180E, same result achieved on CX130E by compacting the recoil spring.
- + Two-piece split cab floor mat for simpler cleaning.
- + Radiator shroud with larger opening from the side and additional opening below the upper structure for better accessibility.



- + Air cleaner height change for easier put on and off.
- + Fan belt auto-tensioner requires no manual calibration.
- + Remote diagnostics and assistance, and interactive maintenance with the new bidirectional CASE SiteConnect module and enhanced SiteWatch telematics services.
- + The new aftermarket offering of CASE **NEXPRO rubber bolt-on pads**, available on CX130E fitted with 500 mm and 600 mm shoes, makes it easy and quick to switch between on- and off-road applications, extending the machine's versatility and improving the customer's profitability.



MAIN REASONS TO CHOOSE THE NEW E-SERIES

BEST MATCH BETWEEN SPEED AND CONTROLLABILITY

CASE Intelligent Hydraulics System (CIHS) is synonymous and reference in the market for its fastest cycles times, best energy saving performance and smooth control.

ENHANCED QUALITY AND RELIABILITY

CASE excavators are known for their balanced design and first-class components. New improvements to arm, boom and undercarriage structure make them even better.

ENHANCED VERSATILITY

- + **NEW** 4 work modes
(Super Power, Power, Eco, Lifting)
- + **NEW** 10 throttle settings, independent from work mode
- + **NEW** arm, boom and swing flow balance customization to suit every application
- + **NEW** attachment types and names storable in the display for quicker tools management

ENHANCED EFFICIENCY

- + **NEW** Eco mode ensures the best selective engine and pump control, maximizing torque only when needed and saving more fuel
- + **NEW** FPT Stage V engine with no EGR, more efficient combustion
- + **NEW** improved travel motor durability and performances

ENHANCED CONNECTIVITY

- + **NEW** bidirectional CASE SiteConnect module
- + **NEW** interactive maintenance capabilities
- + **NEW** remote assistance
- + **NEW** standard CASE full telematics solution (modem, wiring, harnesses, antenna and 3-year advanced SiteWatch subscription)

SUPERIOR VISIBILITY

- + **NEW** 10" LCD monitor – the biggest in the industry – with 5 configurable buttons and new menu functions
- + **NEW** front window defrost and washing improvement
- + **NEW** greater visibility on the right hand side
- + Optional CASE Maximum View Monitor for optimized all-around visibility
- + Optional LED lighting



ENHANCED COMFORT

- + **NEW** console suspended with seat
- + **NEW** wide access space and increased foot space
- + **NEW** dedicated A/C controls in the monitor, always within easy reach
- + **NEW** improved air conditioning with new air vents
- + **NEW** smoother travelling with repositioned rollers
- + **NEW** quieter environment in the cab

EASY MAINTENANCE

- + **NEW** extended 1,000-hour engine oil, fuel & oil filters change interval + 1,000-hour bushing greasing intervals for arm and boom pins
- + **NEW** SCR-on-Filter auto-cleaning device – maintenance-free and built-for-life
- + **NEW** easy access to hydraulic tank thanks to cap with air breather
- + **NEW** split type floor mat
- + **NEW** NEXPRO bolt-on rubber pads aftermarket offering for fast replacement and greater versatility on CX130E.

CLEANER POWER

- + **NEW** STAGE V engine by FPT, the European leader, known for its reliability and innovative tradition, with more than 25 years' experience
- + **NEW** High Efficiency SCR 2 system, covered by 13 patents
- + **NEW** EGR-free
- + **NEW** compatible with HVO and synthetic alternative fuels

SAFER OPERATION AND ACCESSIBILITY

- + ROPS cab with FOPS level 2
- + Standard extended handrails and guardrails
- + Optional factory fitted travel alarm
- + **NEW** auto lever lock safety feature





THE SCIENCE BIT

The CASE SiteWatch telematics system uses a high-tech control unit mounted on each machine to collate information from that machine and from GPS satellites. This data is then sent wirelessly through the mobile communication networks to the CASE Telematics Web Portal.



SITELATCH: CENTRALISED FLEET CONTROL BENEFITS AT YOUR FINGERTIPS

Measure your true asset availability and optimise it

- + Eliminate the “phantom fleet”: SiteWatch allows to identify spare units or under loaded machines on each site.
- + Become able to reallocate units where they are more needed.
- + Forward maintenance planning is easier since the actualised working hours are always available.
- + Extend the benefits of SiteWatch to the rest of your fleet: SiteWatch can be installed on the units of other brands as well.

Challenge your Total Cost of Ownership!

- + Being able to compare the fuel usage of different machine types will allow you choose the right equipment.
- + Save on transport costs with planned and grouped maintenance tasks.
- + Peace of mind, optimised uptime and lower repair costs: with preventive maintenance you can for example be alerted if the engine needs to be serviced and avoid disruptive breakdown.
- + Be able to compare your asset Return on Investment on different sites.
- + Your equipment is used only during working hours. You can set up alerts so that you know if it is in use during the weekend or at night.
- + Integrate with the programmed maintenance package, which ensures the required services are performed at the right time.

More safety, lower insurance premium

- + Keep thieves away: dissuade them from attacking your asset because it is geo-localised. SiteWatch is hidden so that thieves can't find it quickly.
- + Your fleet is used only where you decide. You can define a virtual fence and receive an email when a machine exits that perimeter.

CASE EXPERT SUPPORT

ALWAYS WITH YOU

SITECONNECT: PROACTIVE SUPPORT AND REMOTE ASSISTANCE

The SiteConnect module allows to establish a 2-way communication between your machine and your CASE Dealer. They will be able to run remote diagnostics and analyze the machine data before travelling to the unit.

Maximize your machine's uptime

- + Save time as your dealer conducts remote assistance to the operator. The machine can be anywhere while the dealer remotely connects with the machine to do diagnostics.
- + The dealer is supporting you with SiteConnect tools to maximize the uptime for your machine

Optimize service efficiency

- + By enabling your dealer to investigate your asset remotely, allows them to resolve issues in the shortest possible time, in a single visit, with the correct parts and tools.
- + Electronic control units installed on the machine may be subject to software updates: With the SiteConnect module your CASE Dealer will be able to do software updates on your machine remotely
- + Increase uptime, reduce costs!

Lower your Total Cost of Ownership

- + Thanks to the data collected about your machine condition and performance by Siteconnect, your CASE dealer can provide a quick and effective service, when you need it. This gives you increased Uptime.



Download the SiteManager app to enable remote access to your equipment directly from Dealer facilities, always under your permission. A sticker with a SiteConnect QR code is placed on the right cab pillar. Scan the QR code with your mobile device to quickly access the SiteConnect page, where you can easily download the SiteManager App and get more useful contents.

STANDARD AND OPTIONS

STANDARD EQUIPMENT

ENGINE

- + FPT NEF 4-cylinder turbo-charged diesel
- + Stage V
- + Selective Catalytic Reduction on Filter (SCRoF)
- + Diesel Oxidation Catalyst (DOC)
- + EGR-free
- + VGT turbocharger
- + Electronic fuel injection
- + High pressure common rail system
- + Neutral safety start
- + Auto engine warm up, emergency stop
- + Glow-plug pre-heat
- + EPF (Engine Protection Feature)
- + Dual-stage fuel filtration
- + Dual element air filter
- + Remote oil filter
- + Green plug oil drain
- + 1,000 hour engine oil and fuel filters change interval
- + 24-volt system
- + Battery disconnect switch
- + High ambient temperature cooling package
- + External fuel and AdBlue gauges
- + Fuel cooler
- + Fuel filter + fuel prefilter with water accumulation indicator
- + Fuel shut-off valve
- + Idle start
- + Radiator, oil cooler, intercooler – protective screen
- + Refueling pump

FUEL ECONOMY SYSTEMS

- + Eco mode
- + Auto idle
- + One-touch idle
- + Idle shutdown
- + Pump Torque Control (PTC)
- + Boom Economy Control (BEC)
- + Swing Relief Control (SRF)
- + Spool Stroke Control (SSC)
- + Boom Oil Regeneration (BOR)

OPTIONAL EQUIPMENT

ENGINE

- + Engine oil and hydraulic oil sample port

HYDRAULICS

- + Clamshell circuit
- + Low-flow circuit, proportional control (n.a. on CX130E Long Reach)
- + Single acting hammer circuit with electrical proportional control
- + Multifunction (hammer/high flow) circuit with electrical proportional control (n.a. on CX130E Long Reach)
- + Double acting circuit with electrical proportional control (only on CX130E Long Reach)

HYDRAULICS

- + Hydraulic flow control balance
- + Electronically controlled hydraulic pumps
- + Auto power boost
- + Auto travel speed change
- + 4 selectable work modes
- + Overload warning device
- + ISO pattern controls
- + Pre-set auxiliary pump settings
- + Switch controlled auxiliary selection
- + Auxiliary valve
- + Hydraulic filter restriction indicator
- + Oil cooler
- + 5,000 hour hydraulic oil change interval
- + 2,000 hour hydraulic filter change interval
- + Hydraulic quick coupler provision
- + Hydraulic fluid supply port with air breather

UPPERSTRUCTURE

- + ISO mirrors
- + Handrail – RH access
- + ISO guard rails
- + Isolation mounted cab (fluid and spring)
- + Lifting eyes for counterweight
- + Lockable fuel cap, service doors and toolbox
- + Rear and side view safety camera

OPERATOR STATION

- + ROPS protection
- + FOPS guard OPG level 2
- + Pressurized cab
- + Tempered safety glass
- + One-touch lock front window
- + Sun visor & rain deflector
- + A/C, heating and defrosting with automatic control
- + Luch box & cool box, cup holders & ashtray
- + Interior dome light
- + Multi-adjustable low frequency air suspension console and tiltable seat with air springs and double acting hydraulic damper
- + Sliding seat – 90 mm
- + Seat belt with fasten detection

OPERATOR STATION

- + Heated seat
- + Front cab guard - vertical bars (OPG level 2)
- + Front cab guard - vertical bars (OPG level 1), available as DIA kit
- + Front mesh screen, available as DIA kit
- + Travel alarm
- + AM/FM Bluetooth radio with antenna and 2 speakers
- + 8 LED work lights (2 cab roof, 1 LH boom, 1 toolbox, 4 all-around)
- + Rain deflector
- + CASE Maximum View Monitor - 270° view with additional left side camera

- + Adjustable armrests
- + Low-effort joystick controls
- + Sliding cockpit - 80 mm
- + Auxiliary select system
- + Aux-in port for personal electronics
- + Multifunction LED color monitor (10"), with silicon switches
- + 22 selectable languages for monitor
- + Anti-theft system (start code system)
- + Split type floor mat
- + 12-volt electric socket
- + 24-volt cigarette lighter
- + One-piece right hand window
- + 4 halogen work lights (2 cab roof, 1 LH boom, 1 toolbox)
- + Windshield wiper / washer
- + Clear (Lexan) roof window with sunshade
- + Storage compartments
- + On-board diagnostic system

ATTACHMENTS

- + Standard boom 4.63 m (CX130E) or 5.15 m (CX160E / CX180E)
- + Long reach boom 7.4 m (CX130E Long Reach)
- + Arm 2.50 m (CX130E) or 2.62 m (CX160E / CX180E)
- + Long reach arm 5.3 m (CX130E Long Reach)
- + Attachment types and names storable in the display

UNDERCARRIAGE

- + 600 mm steel triple grouser shoes
- + 700 mm steel triple grouser shoes (only on CX130E Long Reach)
- + Full overlap turntable bearing tub
- + Sealed link chain
- + Lashing points

TELEMATICS

- + SiteConnect module and 3 years advanced SiteWatch subscription with remote monitoring

ATTACHMENTS

- + HD boom 4.63 m (CX130E)
- + Arm HD 2.10 / 3.01 m (CX130E) or 3.05 m (CX160E / CX180E)

UNDERCARRIAGE

- + 500 / 700 mm steel triple grouser shoes (CX130E / CX160E) or 700 / 800 mm steel triple grouser shoes (CX180E)
- + 500 mm rubber link chain (CX130E)
- + Triple track (CX160E / CX180E) or double track guide (CX130E)



SPECIFICATIONS

CX130E

ENGINE

Model _____ FPT NEF4
 Type ___ Water-cooled, 4-cycle diesel, 4-cylinder in line, High pressure common rail system (electric control), turbocharger with air cooled intercooler, SCRoF, EGR free.

Emissions _____ Stage V
 Number of cylinders / Displacement (l) _____ 4 / 4.5
 Bore and stroke (mm) _____ 104 X 132

Rated flywheel horse power

ISO 9249 (kW) _____ 76.4 at 2000 min⁻¹ (rpm)
 ISO 14396 (kW) _____ 78.8 at 2000 min⁻¹ (rpm)

Maximum torque

ISO 9249 (Nm) _____ 370 at 1800 min⁻¹ (rpm)
 ISO 14396 (Nm) _____ 379 at 1800 min⁻¹ (rpm)

HYDRAULIC SYSTEM

Main pumps _____ 2 variable displacement axial piston pumps with regulating system

Max. oil flow (l/min) _____ 2 x 129 at 2000 min⁻¹

Working circuit pressure

Boom/Arm/Bucket (MPa) _____ 34.3 - 36.3 with auto power boost
 Swing circuit (MPa) _____ 27.9
 Travel circuit (MPa) _____ 34.3

Pilot pump _____ 1 gear pump
 Max. oil flow (l/min) _____ 20

Working circuit pressure (MPa) _____ 3.9

Blade pump (CX130E Blade) _____ 1 gear pump

Max. oil flow (l/min) _____ 54 at 2000 min⁻¹
 Working circuit pressure (MPa) _____ 20.6

Boom cylinders

Bore (mm) _____ 105
 Stroke (mm) _____ 961

Arm cylinder

Bore (mm) _____ 115
 Stroke (mm) _____ 1108

Bucket cylinder

Bore (mm) _____ 95
 Stroke (mm) _____ 881

SWING

Swing motor _____ Fixed displacement axial piston motor
 Maximum swing speed (min⁻¹) _____ 14.3
 Swing torque (Nm) _____ 33,000

FILTERS

Suction filter (µm) _____ 105
 Return filter (µm) _____ 6
 Pilot line filter (µm) _____ 8

ELECTRICAL SYSTEM

Voltage (V) _____ 24
 Alternator (Amp) _____ 90
 Starter (V - kW) _____ 24 - 4.0
 Battery _____ 2 X 12 V 72 Ah/5HR

UNDERCARRIAGE

Travel motor _____ Variable displacement axial piston motor
 High travel speed (Automatic travel speed shifting) (km/h) _ 5.7
 Low travel speed (km/h) _____ 3.4
 Drawbar pull (kN) _____ 116
 Number of carrier rollers (each side) _____ 2
 Number of track rollers (each side) _____ 7
 Number of shoes (each side) _____ 46
 Type of shoes _____ Triple grouser shoes
 Gradeability _____ 70% (35°)

NOISE (PRELIMINARY)

External guaranteed sound level
 (EU Directive 2000/14/EC) _____ LwA 99 dB(A)
 Operator cab sound pressure level (ISO 6396) _ LpA 69 dB(A)

CIRCUIT AND COMPONENT CAPACITIES

Fuel tank (l) _____ 250
 Hydraulic system (l) _____ 157
 Hydraulic tank (l) _____ 82
 AdBlue tank (l) _____ 60

| PERFORMANCE DATA | | Arm 2.50 m | Arm 3.01 m | Arm 2.11 m |
|------------------------|----|------------|------------|------------|
| Boom length | mm | 4630 | 4630 | 4630 |
| Bucket radius | mm | 1200 | 1200 | 1200 |
| Bucket wrist action | ° | 178 | 178 | 178 |
| A Maximum reach at GRP | mm | 8170 | 8640 | 7810 |
| B Maximum reach | mm | 8310 | 8770 | 7960 |
| C Max. digging depth | mm | 5550 | 6050 | 5160 |
| D Max. digging height | mm | 8770 | 9050 | 8550 |
| E Max. dumping height | mm | 6390 | 6680 | 6170 |
| F Min. swing radius | mm | 2340 | 2660 | 2360 |

| DIGGING FORCE (ISO 6015) | | Arm 2.50 m | Arm 3.01 m | Arm 2.11 m |
|--------------------------|----|------------|------------|------------|
| Arm digging force | kN | 62 | 56 | 70 |
| with Auto power up | kN | 66 | 60 | 74 |
| Bucket digging force | kN | 90 | 90 | 90 |
| with Auto power up | kN | 95 | 95 | 95 |

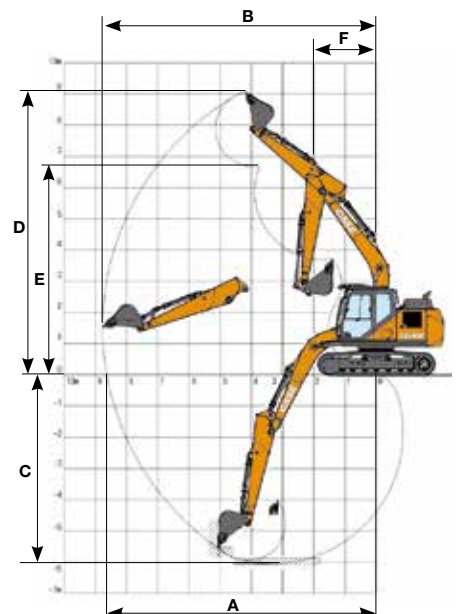

SPECIFICATIONS

CX130E BLADE-LC

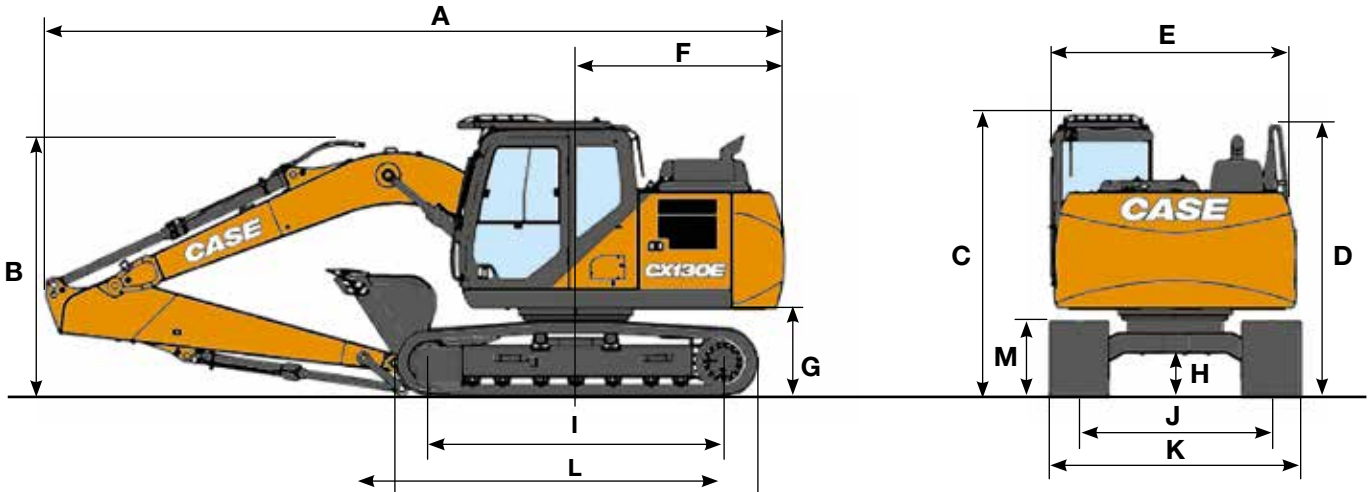

| GENERAL DIMENSIONS | Arm 2.50 m | Arm 3.01 m | Arm 2.11 m |
|--|----------------|-------------|-------------|
| Overall length (without attachment) (Blade/LC) | mm 4160 / 4050 | 4160 / 4050 | 4160 / 4050 |
| A Overall length (with attachment) (Blade/LC) | mm 7900 / 7660 | 7910 / 7680 | 7890 / 7660 |
| B Overall height (to top of boom) | mm 2760 | 2740 | 2670 |
| C Cab height | mm 2910 | 2910 | 2910 |
| D Overall height (to top of handrail) | mm 2800 | 2800 | 2800 |
| E Upper structure overall width | mm 2490 | 2490 | 2490 |
| F Swing (rear end radius) | mm 2190 | 2190 | 2190 |
| G Clearance height under upper structure | mm 900 | 900 | 900 |
| H Minimum ground clearance (Blade/LC) | mm 425 / 420 | 425 / 420 | 425 / 420 |
| I Wheel base (center to center of wheels) (Blade/LC) | mm 2790 / 3040 | 2790 / 3040 | 2790 / 3040 |
| J Track gauge | mm 1990 | 1990 | 1990 |
| K Undercarriage overall width (with 600 mm shoes) | mm 2590 | 2590 | 2590 |
| L Crawler overall length (Blade/LC) | mm 3500 / 3760 | 3500 / 3760 | 3500 / 3760 |
| M Crawler tracks height | mm 780 | 780 | 780 |

WEIGHT AND GROUND PRESSURE

With 2.50 m arm, 0.5 m³ bucket, 600 mm grouser shoes, operator, lubricant, coolant, full fuel tank and FOPS protection level 2.

| | WEIGHT | GROUND PRESSURE |
|-------|----------|-----------------|
| Blade | 13900 kg | 0.037 MPa |
| LC | 13300 kg | 0.033 MPa |

Counterweight: 1870 kg

With 5.30 m arm, 0.28 m³ bucket, 700 mm grouser shoes, operator, lubricant, coolant, full fuel tank.

| | WEIGHT | GROUND PRESSURE |
|----|----------|-----------------|
| LR | 15400 kg | 0.033 MPa |

Counterweight: 3400 kg

HAMMER

CX130E

Direct Fit

| Model | Install Weight kg | Reference machine settings | | Arm 2.11 m | Arm 2.50 m | Arm 3.01 m |
|-------------------|----------------------|----------------------------|------------------------|--------------------------|--------------------------|--------------------------|
| | | Flow l/min | Relief Pressure Mpa | | | |
| CB BREAKER | | | | | | |
| CB135S | 630 | 87 | 18-21 | <input type="checkbox"/> | <input type="checkbox"/> | <input type="checkbox"/> |
| CB150S | 950 | 87 | 19-21 | <input type="checkbox"/> | — | — |

Applicable
 — Not applicable

SPECIFICATIONS (PRELIMINARY)

CX130E LONG REACH

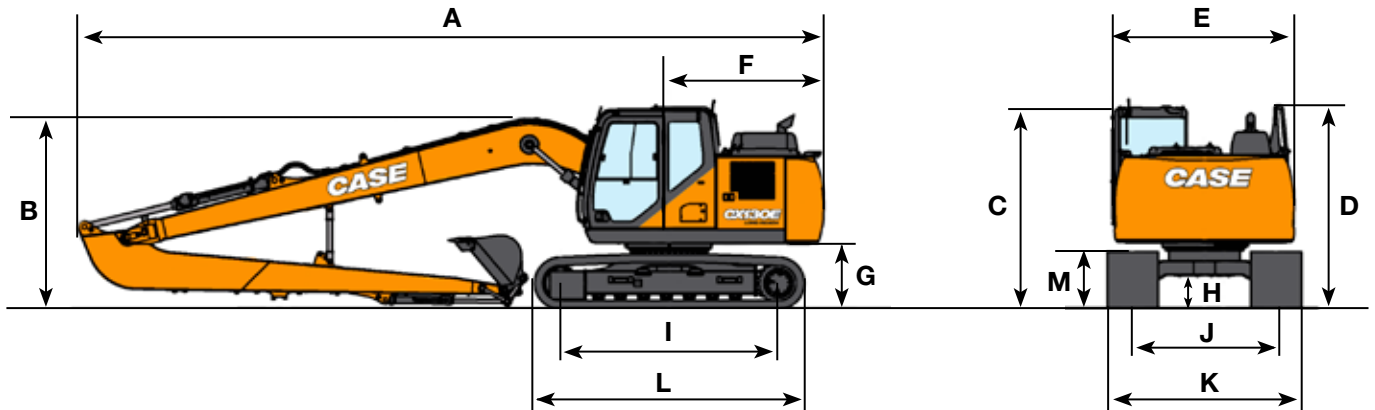

GENERAL DIMENSIONS

Arm 5.30 m

| | | |
|---|----|-------|
| Overall length (without attachment) | mm | 4030 |
| A Overall length (with attachment) | mm | 10390 |
| B Overall height (to top of boom) | mm | 2660 |
| C Cab height | mm | 2800 |
| D Overall height (to top of handrail) | mm | 2810 |
| E Upper structure overall width | mm | 2530 |
| F Swing (rear end radius) | mm | 2190 |
| G Clearance height under upper structure | mm | 895 |
| H Minimum ground clearance | mm | 420 |
| I Wheel base (center to center of wheels) | mm | 3040 |
| L Crawler overall length | mm | 3760 |
| M Crawler tracks height | mm | 780 |
| J Track gauge | mm | 1990 |
| K Undercarriage overall width (with 700 mm shoes) | mm | 2590 |

PERFORMANCE DATA

Arm 5.30 m

| | | |
|------------------------|----|-------|
| Boom length | mm | 7400 |
| Bucket radius | mm | 1050 |
| Bucket wrist action | | 180° |
| A Maximum reach at GRP | mm | 13010 |
| B Maximum reach | mm | 13100 |
| C Max. digging depth | mm | 10130 |
| D Max. digging height | mm | 12070 |
| E Max. dumping height | mm | 10080 |
| F Min. swing radius | mm | 3220 |

DIGGING FORCE (ISO 6015)





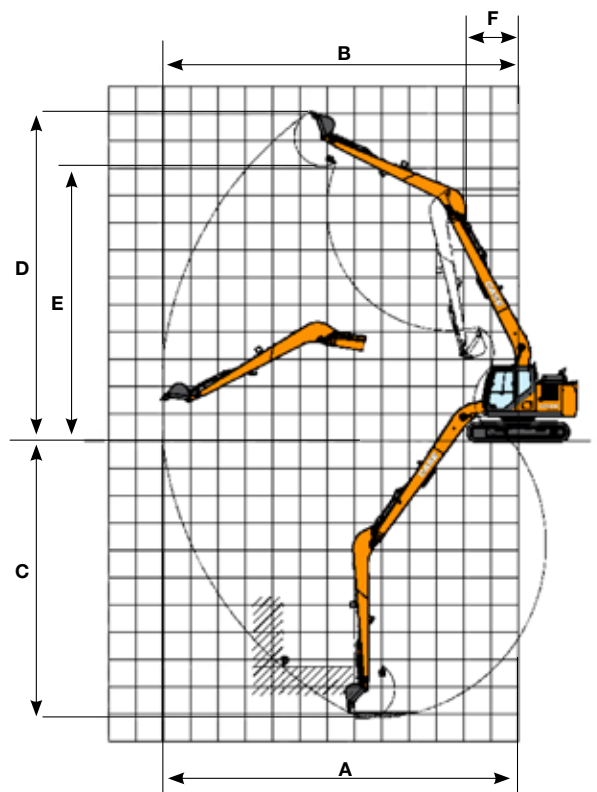



Arm 5.30 m

| | |
|----------------------|-------|
| Arm digging force | 23 kN |
| Bucket digging force | 35 kN |



LIFTING CAPACITY

CX130E BLADE-LC

| | | REACH | | | | | | | | | |
|---|---|---|---|---|---|---|---|---|--|--|------|
| Front Side | 2.0 m | | 4.0 m | | 6.0 m | | At max reach | | | | m |
| |  |  |  |  |  |  |  |  | | | |
| BLADE DOWN - Short arm 2.11 m, 600 mm shoes, max reach 6.76 m | | | | | | | | | | | |
| 6.0 m | | | 3600* | 3600* | | | 2730* | 2730* | | | 5.00 |
| 4.0 m | | | 4270* | 4270* | 3800* | 2510 | 2440* | 2330 | | | 6.27 |
| 2.0 m | | | 5970* | 4330 | 4190* | 2410 | 2490* | 2020 | | | 6.74 |
| 0 m | | | 6990* | 4050 | 4540* | 2310 | 2840* | 2040 | | | 6.58 |
| -2.0 m | 7910* | 7910* | 6620* | 4030 | | | 3840* | 2460 | | | 5.74 |
| BLADE DOWN - Standard arm 2.50 m, 600 mm shoes, max reach 7.11 m | | | | | | | | | | | |
| 6.0 m | | | | | | | 2200* | 2200* | | | 5.47 |
| 4.0 m | | | 3870* | 3870* | 3550* | 2570 | 2010* | 2010* | | | 6.65 |
| 2.0 m | | | 5650* | 4430 | 4050* | 2450 | 2060* | 1900 | | | 7.09 |
| 0 m | | | 6920* | 4110 | 4510* | 2340 | 2340* | 1910 | | | 6.94 |
| -2.0 m | 7160* | 7160* | 6840* | 4040 | 4300* | 2320 | 3080* | 2250 | | | 6.15 |
| -4.0 m | | | 4810* | 4210 | | | 4130* | 3710 | | | 4.39 |
| BLADE DOWN - Long arm 3.01 m, 600 mm shoes, max reach 7.57 m | | | | | | | | | | | |
| 6.0 m | | | | | 2170* | 2170* | 2000* | 2000* | | | 6.06 |
| 4.0 m | | | | | 3170* | 2580 | 1850* | 1850* | | | 7.14 |
| 2.0 m | | | 5070* | 4470 | 3750* | 2440 | 1910* | 1700 | | | 7.55 |
| 0 m | | | 6620* | 4080 | 4340* | 2300 | 2140* | 1700 | | | 7.41 |
| -2.0 m | 6350* | 6350* | 6890* | 3950 | 4410* | 2240 | 2730* | 1950 | | | 6.68 |
| -4.0 m | 10230* | 10230* | 5580* | 4050 | | | 3970* | 2890 | | | 5.11 |
| BLADE UP - Short arm 2.11 m, 600 mm shoes, max reach 6.76 m | | | | | | | | | | | |
| 6.0 m | | | 3600* | 3600* | | | 2730* | 2730* | | | 5.00 |
| 4.0 m | | | 4270* | 4270* | 3080 | 2360 | 2440* | 2190 | | | 6.27 |
| 2.0 m | | | 5520 | 4030 | 2970 | 2260 | 2490 | 1890 | | | 6.74 |
| 0 m | | | 5210 | 3770 | 2870 | 2160 | 2520 | 1910 | | | 6.58 |
| -2.0 m | 7910* | 7910* | 5190 | 3740 | | | 3060 | 2300 | | | 5.74 |
| BLADE UP - Standard arm 2.50 m, 600 mm shoes, max reach 7.11 m | | | | | | | | | | | |
| 6.0 m | | | | | | | 2200* | 2200* | | | 5.47 |
| 4.0 m | | | 3870* | 3870* | 3140 | 2420 | 2010* | 2010* | | | 6.65 |
| 2.0 m | | | 5620 | 4130 | 3010 | 2300 | 2060* | 1780 | | | 7.09 |
| 0 m | | | 5270 | 3820 | 2890 | 2190 | 2340* | 1790 | | | 6.94 |
| -2.0 m | 7160* | 7160* | 5200 | 3760 | 2870 | 2170 | 2780 | 2100 | | | 6.15 |
| -4.0 m | | | 4810* | 3910 | | | 4130* | 3460 | | | 4.39 |
| BLADE UP - Long arm 3.01 m, 600 mm shoes, max reach 7.57 m | | | | | | | | | | | |
| 6.0 m | | | | | 2170* | 2170* | 2000* | 2000* | | | 6.06 |
| 4.0 m | | | | | 3160 | 2430 | 1850* | 1800 | | | 7.14 |
| 2.0 m | | | 5070* | 4170 | 3000 | 2290 | 1910* | 1590 | | | 7.55 |
| 0 m | | | 5240 | 3790 | 2850 | 2150 | 2100 | 1590 | | | 7.41 |
| -2.0 m | 6350* | 6350* | 5100 | 3660 | 2790 | 2090 | 2410 | 1820 | | | 6.68 |
| -4.0 m | 10230* | 10230* | 5210 | 3760 | | | 3620 | 2700 | | | 5.11 |

* The above loads (kg) are compliant to the ISO standards and refer to the excavator equipped without bucket. The indicated loads are no more than 87% of hydraulic system lift capacity or 75% of static tipping load. Values marked with an asterisk (*) are limited by the hydraulic lifting capacity.

LIFTING CAPACITY

CX130E BLADE-LC

| | | REACH | | | | | | | | | |
|---|--------|--------|-------|-------|-------|-------|--------------|-------|-------|------|------|
| Front Side | 2.0 m | | 4.0 m | | 6.0 m | | At max reach | | | | m |
| | Front | Side | Front | Side | Front | Side | Front | Side | Front | Side | |
| LC UNDERCARRIAGE - Short arm 2.11 m, 600 mm shoes, max reach 6.76 m | | | | | | | | | | | |
| 6.0 m | | | 3600* | 3600* | | | 2730* | 2730* | | | 5.00 |
| 4.0 m | | | 4270* | 4270* | 3440 | 2260 | 2440* | 2090 | | | 6.27 |
| 2.0 m | | | 5970* | 3860 | 3330 | 2160 | 2490* | 1810 | | | 6.74 |
| 0 m | | | 5980 | 3600 | 3220 | 2060 | 2820 | 1820 | | | 6.58 |
| -2.0 m | 7910* | 7910* | 5950 | 3570 | | | 3440 | 2200 | | | 5.74 |
| LC UNDERCARRIAGE - Standard arm 2.50 m, 600 mm shoes, max reach 7.11 m | | | | | | | | | | | |
| 6.0 m | | | | | | | 2200* | 2200* | | | 5.47 |
| 4.0 m | | | 3870* | 3870* | 3500 | 2320 | 2010* | 1950 | | | 6.65 |
| 2.0 m | | | 5650* | 3960 | 3370 | 2200 | 2060* | 1700 | | | 7.09 |
| 0 m | | | 6040 | 3650 | 3250 | 2090 | 2340* | 1710 | | | 6.94 |
| -2.0 m | 7160* | 7160* | 5960 | 3590 | 3220 | 2070 | 3080* | 2000 | | | 6.15 |
| -4.0 m | | | 4810* | 3750 | | | 4130* | 3310 | | | 4.39 |
| LC UNDERCARRIAGE - Long arm 3.01 m, 600 mm shoes, max reach 7.57 m | | | | | | | | | | | |
| 6.0 m | | | | | 2170* | 2170* | 2000* | 2000* | | | 6.06 |
| 4.0 m | | | | | 3170* | 2330 | 1850* | 1720 | | | 7.14 |
| 2.0 m | | | 5070* | 4010 | 3360 | 2190 | 1910* | 1520 | | | 7.55 |
| 0 m | | | 6010 | 3620 | 3210 | 2040 | 2140* | 1510 | | | 7.41 |
| -2.0 m | 6350* | 6350* | 5860 | 3490 | 3150 | 1990 | 2710 | 1730 | | | 6.68 |
| -4.0 m | 10230* | 10230* | 5580* | 3590 | | | 3970* | 2570 | | | 5.11 |

LIFTING CAPACITY (PRELIMINARY)

CX130E LONG REACH

| | | REACH | | | | | | | | | | | | | |
|---|-------|-------|-------|-------|-------|-------|-------|-------|--------|------|--------|------|--------------|------|-------|
| Front Side | 2.0 m | | 4.0 m | | 6.0 m | | 8.0 m | | 10.0 m | | 12.0 m | | At max reach | | m |
| | Front | Side | Front | Side | Front | Side | Front | Side | Front | Side | Front | Side | Front | Side | |
| 5.30 m length, 750 LC mm shoes, max reach 12.00 m | | | | | | | | | | | | | | | |
| 10.0 m | | | | | | | 1030* | 1030* | | | | | 720* | 720* | 8.49 |
| 8.0 m | | | | | | | 1400* | 1400* | 760* | 760* | | | 660* | 660* | 10.12 |
| 6.0 m | | | | | | | 1530* | 1530* | 1440* | 1360 | | | 640* | 640* | 11.17 |
| 4.0 m | | | | | 2050* | 2050* | 1800* | 1800* | 1650* | 1300 | | | 660* | 660* | 11.79 |
| 2.0 m | | | 4310* | 4310* | 2760* | 2630 | 2150* | 1730 | 1840* | 1210 | 750* | 750* | 710* | 710* | 12.04 |
| 0 m | | | 2770* | 2770* | 3390* | 2310 | 2450 | 1560 | 1770 | 1120 | | | 790* | 790* | 11.95 |
| -1.5 m | 1420* | 1420* | 2690* | 2690* | 3460 | 2120 | 2320 | 1450 | 1700 | 1060 | | | 930* | 860 | 11.52 |
| -4.0 m | 2060* | 2060* | 3280* | 3280* | 3390 | 2060 | 2270 | 1400 | 1680 | 1030 | | | 1190* | 950 | 10.69 |
| -6.0 m | 2770* | 2770* | 4240* | 3750 | 3430 | 2090 | 2300 | 1420 | | | | | 1750* | 1160 | 9.37 |
| -8.0 m | | | 4140* | 3990 | 2860* | 2230 | | | | | | | 2240* | 1740 | 7.29 |

BUCKETS

CX130E

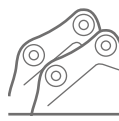

CX130E - Direct Mount

| Capacity m ³ (ISO7451 HEAPED) | Width mm | Weight kg | Arm 2.11 m | Arm 2.50 m | Arm 3.01 m |
|---|-------------|---------------|---------------|---------------|---------------|
| GENERAL PURPOSE BUCKETS | | | | | |
| 0.21 | 450 | 250 | ○ | ○ | ○ |
| 0.31 | 600 | 290 | ○ | ○ | ○ |
| 0.41 | 750 | 330 | ○ | ○ | ○ |
| 0.52 | 900 | 360 | ○ | ○ | ○ |
| 0.58 | 1000 | 400 | ○ | ○ | ● |
| 0.66 | 1100 | 430 | ● | ● | ▲ |
| 0.73 | 1200 | 450 | ● | ▲ | ■ |
| HEAVY DUTY BUCKETS | | | | | |
| 0.21 | 450 | 350 | ○ | ○ | ○ |
| 0.31 | 600 | 400 | ○ | ○ | ○ |
| 0.42 | 750 | 460 | ○ | ○ | ○ |
| 0.45 | 800 | 470 | ○ | ○ | ○ |
| 0.52 | 900 | 510 | ○ | ○ | ● |
| 0.60 | 1000 | 550 | ○ | ● | ▲ |
| 0.67 | 1100 | 580 | ● | ▲ | ■ |
| 0.74 | 1200 | 620 | ▲ | ■ | — |
| Capacity m ³ (ISO7451 HEAPED) | Width mm | Weight* kg | Arm 2.11 m | Arm 2.50 m | Arm 3.01 m |
| GRADING BUCKETS | | | | | |
| 0.59 | 1500 | 440 | ○ | ● | ● |
| 0.72 | 1800 | 510 | ● | ▲ | ■ |
| 0.80 | 2000 | 550 | ▲ | ■ | — |
| DITCH CLEANING BUCKETS | | | | | |
| 0.54 | 1830 | 480 | ○ | ○ | ● |
| 90° TILT DITCH CLEANING BUCKETS** | | | | | |
| 0.46 | 1500 | 640 | ○ | ● | ▲ |
| 0.55 | 1800 | 690 | ● | ▲ | ■ |
| 0.61 | 2000 | 730 | ▲ | ■ | — |



CX130E - Quick coupled

| Capacity m ³ (ISO7451 HEAPED) | Width mm | Weight kg | Arm 2.11 m | Arm 2.50 m | Arm 3.01 m |
|---|-------------|---------------|---------------|---------------|---------------|
| GENERAL PURPOSE BUCKETS | | | | | |
| 0.21 | 450 | 250 | ○ | ○ | ○ |
| 0.31 | 600 | 290 | ○ | ○ | ○ |
| 0.41 | 750 | 330 | ○ | ○ | ○ |
| 0.52 | 900 | 360 | ○ | ○ | ● |
| 0.58 | 1000 | 400 | ● | ● | ▲ |
| 0.66 | 1100 | 430 | ● | ▲ | ■ |
| 0.73 | 1200 | 450 | ▲ | ■ | — |
| HEAVY DUTY BUCKETS | | | | | |
| 0.21 | 450 | 350 | ○ | ○ | ○ |
| 0.31 | 600 | 400 | ○ | ○ | ○ |
| 0.42 | 750 | 460 | ○ | ○ | ● |
| 0.45 | 800 | 470 | ○ | ○ | ● |
| 0.52 | 900 | 510 | ○ | ● | ▲ |
| 0.60 | 1000 | 550 | ● | ▲ | ■ |
| 0.67 | 1100 | 580 | ▲ | ■ | — |
| 0.74 | 1200 | 620 | ■ | — | — |
| Capacity m ³ (ISO7451 HEAPED) | Width mm | Weight* kg | Arm 2.11 m | Arm 2.50 m | Arm 3.01 m |
| GRADING BUCKETS | | | | | |
| 0.59 | 1500 | 440 | ● | ● | ■ |
| 0.72 | 1800 | 510 | ▲ | ■ | — |
| 0.80 | 2000 | 550 | ■ | — | — |
| DITCH CLEANING BUCKETS | | | | | |
| 0.54 | 1830 | 480 | ● | ● | ▲ |

* with bolt-on cutting edge

**Tilt angle 45° L/R Connect to Low-Flow Auxiliary Hydraulic Circuit

BUCKETS (PRELIMINARY)

CX130E LONG REACH



CX130E LR- Direct Mount

| Capacity m ³ (ISO7451 HEAPED) | Width mm | Weight kg | Arm 5.30 m |
|---|-------------|--------------|---------------|
| GENERAL PURPOSE BUCKET | | | |
| 0.10 | 300 | 125 | ○ |
| 0.12 | 350 | 130 | ○ |
| 0.15 | 400 | 140 | ○ |
| 0.17 | 450 | 145 | ○ |
| 0.19 | 500 | 150 | ○ |
| 0.24 | 600 | 170 | ● |
| 0.32 | 750 | 200 | ■ |
| DITCH CLEANING BUCKET | | | |
| 0.27 | 1200 | 170 | ● |
| 0.35 | 1500 | 200 | ■ |



CX130E LR - Quick coupled

| Capacity m ³ (ISO7451 HEAPED) | Width mm | Weight kg | Arm 5.30 m |
|---|-------------|--------------|---------------|
| GENERAL PURPOSE SCOOP BUCKET | | | |
| 0.10 | 300 | 125 | ○ |
| 0.12 | 350 | 130 | ○ |
| 0.15 | 400 | 140 | ○ |
| 0.17 | 450 | 145 | ○ |
| 0.19 | 500 | 150 | ○ |
| 0.24 | 600 | 170 | ● |
| 0.32 | 750 | 200 | ■ |
| DITCH CLEANING BUCKET | | | |
| 0.27 | 1200 | 180 | ■ |

- Rated material density up to 2 ton/m³
- Rated material density up to 1.6 ton/m³
- ▲ Rated material density up to 1.4 ton/m³

- Rated material density up to 1.2 ton/m³
- Not applicable

SPECIFICATIONS

CX160E

ENGINE

Model FPT NEF4
 Type Water-cooled, 4-cycle diesel, 4-cylinder in line,
High pressure common rail system (electric control),
turbocharger with air cooled intercooler, SCRoF, EGR free.
 Emissions Stage V
 Number of cylinders / Displacement (l) 4 / 4.5
 Bore and stroke (mm) 104 x 132
Rated flywheel horse power
 ISO 9249 (kW) 90.4 at 2200 min⁻¹ (rpm)
 ISO 14396 (kW) 96.5 at 2200 min⁻¹ (rpm)
Maximum torque
 ISO 9249 (Nm) 456 at 1600 min⁻¹ (rpm)
 ISO 14396 (Nm) 470 at 1600 min⁻¹ (rpm)

HYDRAULIC SYSTEM

Main pumps 2 variable displacement axial
piston pumps with regulating system
 Max. oil flow (l/min) 2 x 159 at 2200 min⁻¹
Working circuit pressure
 Boom/Arm/Bucket (MPa) 34.3 - 36.3 with auto power boost
 Swing circuit (MPa) 27.9
 Travel circuit (MPa) 34.3
 Pilot pump 1 gear pump
 Max. oil flow (l/min) 22
 Working circuit pressure (MPa) 3.9
Boom cylinders
 Bore (mm) 115
 Stroke (mm) 1179
Arm cylinder
 Bore (mm) 125
 Stroke (mm) 1280
Bucket cylinder
 Bore (mm) 105
 Stroke (mm) 985

SWING

Swing motor Fixed displacement axial piston motor
 Maximum swing speed (min⁻¹) 11.8
 Swing torque (Nm) 45,100

FILTERS

Suction filter (µm) 105
 Return filter (µm) 6
 Pilot line filter (µm) 8

ELECTRICAL SYSTEM

Voltage (V) 24
 Alternator (Amp) 50
 Starter (V - kW) 24 - 4.0
 Battery 2 X 12 V - 72 Ah/5HR

UNDERCARRIAGE

Travel motor Variable displacement axial piston motor
Travel speeds
 High travel speed
 (Automatic travel speed shifting) (km/h) 5.2
 Low travel speed (km/h) 3.0
 Drawbar pull (kN) 161
 Number of carrier rollers (each side) 2
 Number of track rollers (each side) 7
 Number of shoes (each side) 44
 Type of shoes Triple grouser shoes
 Gradeability 70% (35°)

NOISE (PRELIMINARY)

External guaranteed sound level
 (EU Directive 2000/14/EC) (dB(A)) LwA 100
 Operator cab sound pressure level
 (ISO 6396) (dB(A)) LpA 69

CIRCUIT AND COMPONENT CAPACITIES

Fuel tank (l) 300
 Hydraulic system (l) 170
 Hydraulic tank (l) 82
 AdBlue tank (l) 60

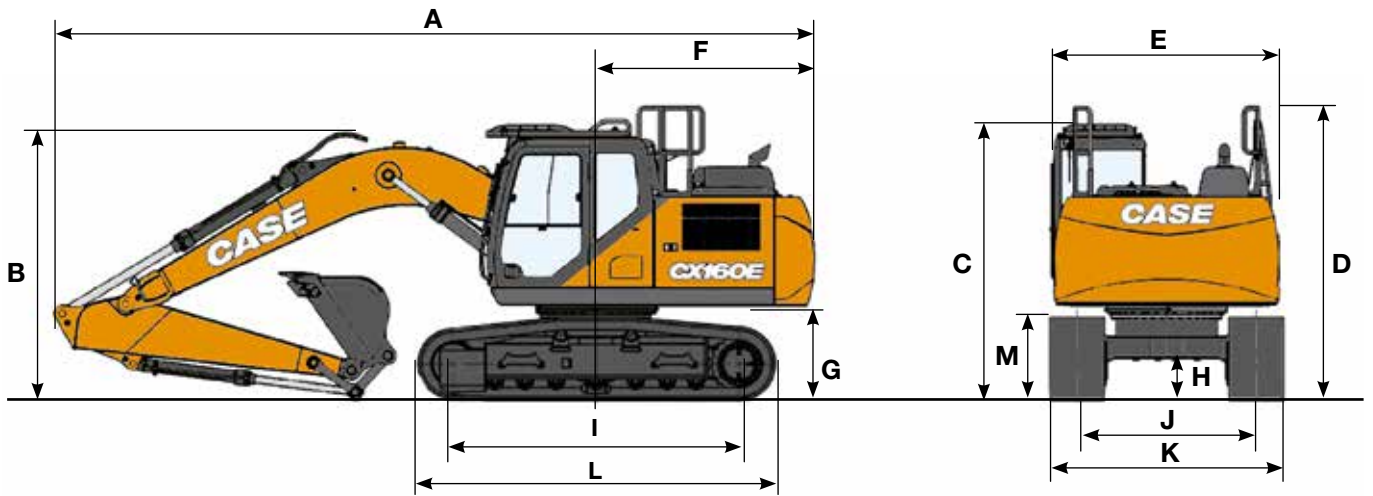

| GENERAL DIMENSIONS | | Arm 2.62 m | Arm 3.05 m |
|---|----|------------|------------|
| Overall length (without attachment) | mm | 4480 | 4480 |
| A Overall length (with attachment) | mm | 8520 | 8570 |
| B Overall height (to top of boom) | mm | 2960 | 3130 |
| C Cab height | mm | 3050 | 3050 |
| D Overall height (to top of handrail) | mm | 3140 | 3140 |
| E Upper structure overall width | mm | 2520 | 2520 |
| F Swing (rear end radius) | mm | 2520 | 2520 |
| G Clearance height under upper structure | mm | 1030 | 1030 |
| H Minimum ground clearance | mm | 420 | 420 |
| I Wheel base (Center to center of wheels) | mm | 3190 | 3190 |
| J Track gauge | mm | 1990 | 1990 |
| K Undercarriage overall width (with 600 mm shoes) | mm | 2590 | 2590 |
| L Crawler overall length | mm | 3990 | 3990 |
| M Crawler tracks height | mm | 920 | 920 |

WEIGHT AND GROUND PRESSURE

With 2.62 m arm, 0.62 m³ bucket , 600 mm grouser shoes, operator, lubricant, coolant, full fuel tank and FOPS protection level 2.

| | WEIGHT | GROUND PRESSURE |
|----|----------|-----------------|
| LC | 17300 kg | 0.041 MPa |

Counterweight: 2820 kg

| PERFORMANCE DATA | | Arm 2.62 m | Arm 3.05 m |
|------------------------|----|------------|------------|
| Boom length | mm | 5150 | 5150 |
| Bucket radius | mm | 1350 | 1350 |
| Bucket wrist action | ° | 178 | 178 |
| A Maximum reach at GRP | mm | 8870 | 9220 |
| B Maximum reach | mm | 9040 | 9380 |
| C Max. digging depth | mm | 6060 | 6490 |
| D Max. digging height | mm | 9240 | 9290 |
| E Max. dumping height | mm | 6610 | 6690 |
| F Min. swing radius | mm | 2990 | 3050 |

| DIGGING FORCE (ISO 6015) | | Arm 2.62 m | Arm 3.05 m |
|--------------------------|----|------------|------------|
| Arm digging force | kN | 79 | 72 |
| with Auto power up | kN | 84 | 77 |
| Bucket digging force | kN | 112 | 112 |
| with Auto power up | kN | 118 | 118 |

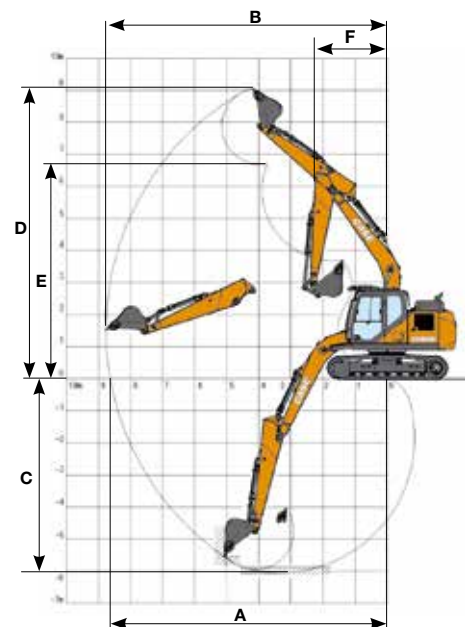

LIFTING CAPACITY

CX160E

| REACH | | | | | | | | | |
|---------------|---|--------|-------|-------|-------|------|--------------|-------|------|
| Front Side | 2.0 m | | 4.0 m | | 6.0 m | | At max reach | | m |
| | Standard arm 2.62 m, 600 mm shoes, max reach 7.69 m | | | | | | | | |
| 6.0 m | | | | | 3920* | 3390 | 2660* | 2660* | 6.37 |
| 4.0 m | | | 6090* | 6090* | 5080 | 3290 | 2540* | 2360 | 7.34 |
| 2.0 m | | | 8890* | 5410 | 4830 | 3070 | 2650* | 2120 | 7.69 |
| 0 m | | | 8660 | 5010 | 4630 | 2880 | 3010* | 2130 | 7.49 |
| -2.0 m | 8100* | 8100* | 8570 | 4940 | 4570 | 2830 | 3920* | 2470 | 6.70 |
| -4.0 m | 13670* | 13670* | 8060* | 5120 | | | 5960* | 3730 | 5.05 |

| REACH | | | | | | | | | | | |
|---------------|---|--------|-------|------|-------|------|-------|------|--------------|-------|------|
| Front Side | 2.0 m | | 4.0 m | | 6.0 m | | 8.0 m | | At max reach | | m |
| | Long arm 3.05 m, 600 mm shoes, max reach 8.03 m | | | | | | | | | | |
| 8.0 m | | | | | | | | | 2820* | 2820* | 4.94 |
| 6.0 m | | | | | 3850* | 3440 | | | 2380* | 2380* | 6.78 |
| 4.0 m | | | | | 4690* | 3310 | | | 2310* | 2180 | 7.70 |
| 2.0 m | | | 8240* | 5410 | 4840 | 3070 | 2570* | 1970 | 2440* | 1960 | 8.03 |
| 0 m | | | 8650 | 4940 | 4610 | 2860 | | | 2790* | 1960 | 7.84 |
| -2.0 m | 7650* | 7650* | 8490 | 4830 | 4510 | 2770 | | | 3570 | 2230 | 7.09 |
| -4.0 m | 14120* | 14120* | 8640 | 4960 | | | | | 5160 | 3180 | 5.56 |

* The above loads (kg) are compliant to the ISO standards and refer to the excavator equipped without bucket. The indicated loads are no more than 87% of hydraulic system lift capacity or 75% of static tipping load. Values marked with an asterisk (*) are limited by the hydraulic lifting capacity.

HAMMER

CX160E

Direct Fit

| Model | Install Weight kg | Reference machine settings | | Arm 2.62 m | Arm 3.05 m |
|-------------------|----------------------|----------------------------|------------------------|---------------|---------------|
| | | Flow l/min | Relief Pressure Mpa | | |
| CB BREAKER | | | | | |
| CB150S | 970 | 95 | 19-21 | □ | — |
| CB240S | 1100 | 95 | 19-21 | — | — |

□ Applicable
— Not applicable

BUCKETS

CX160E

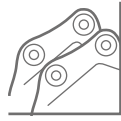

CX160E - Direct Mount

| Capacity m ³ (ISO7451 HEAPED) | Width mm | Weight kg | Arm 2.62 m | Arm 3.05 m |
|---|-------------|--------------|---------------|---------------|
| GENERAL PURPOSE BUCKETS | | | | |
| 0.24 | 450 | 350 | ○ | ○ |
| 0.36 | 600 | 390 | ○ | ○ |
| 0.50 | 750 | 440 | ○ | ○ |
| 0.62 | 900 | 480 | ○ | ○ |
| 0.70 | 1000 | 500 | ○ | ● |
| 0.78 | 1100 | 540 | ● | ▲ |
| 0.87 | 1200 | 570 | ▲ | ■ |
| 1.00 | 1350 | 630 | ■ | — |
| HEAVY DUTY BUCKETS | | | | |
| 0.26 | 450 | 420 | ○ | ○ |
| 0.38 | 600 | 480 | ○ | ○ |
| 0.51 | 750 | 550 | ○ | ○ |
| 0.65 | 900 | 620 | ○ | ● |
| 0.70 | 1000 | 660 | ○ | ● |
| 0.75 | 1050 | 680 | ● | ● |
| 0.78 | 1100 | 700 | ● | ▲ |
| 0.91 | 1200 | 740 | ▲ | ■ |
| 1.00 | 1300 | 800 | ■ | — |
| GRADING BUCKETS | | | | |
| 0.59 | 1500 | 440 | ○ | ○ |
| 0.72 | 1800 | 510 | ○ | ● |
| 0.85 | 2100 | 570 | ● | ▲ |
| DITCH CLEANING BUCKETS | | | | |
| 0.86 | 1830 | 630 | ● | ▲ |
| 90° TILT DITCH CLEANING BUCKETS** | | | | |
| 0.46 | 1500 | 650 | ○ | ○ |
| 0.55 | 1800 | 700 | ○ | ● |
| 0.61 | 2000 | 740 | ● | ▲ |
| 0.68 | 2200 | 810 | ▲ | ■ |
| 0.74 | 2400 | 840 | ■ | — |

CX160E - Quick coupled

| Capacity m ³ (ISO7451 HEAPED) | Width mm | Weight kg | Arm 2.62 m | Arm 3.05 m |
|---|-------------|--------------|---------------|---------------|
| GENERAL PURPOSE BUCKETS | | | | |
| 0.24 | 450 | 350 | ○ | ○ |
| 0.36 | 600 | 390 | ○ | ○ |
| 0.50 | 750 | 440 | ○ | ○ |
| 0.62 | 900 | 480 | ○ | ● |
| 0.70 | 1000 | 500 | ● | ▲ |
| 0.78 | 1100 | 540 | ▲ | ■ |
| 0.87 | 1200 | 570 | ■ | — |
| HEAVY DUTY BUCKETS | | | | |
| 0.26 | 450 | 420 | ○ | ○ |
| 0.38 | 600 | 480 | ○ | ○ |
| 0.51 | 750 | 550 | ○ | ● |
| 0.65 | 900 | 620 | ● | ▲ |
| 0.70 | 1000 | 660 | ▲ | ■ |
| 0.75 | 1050 | 680 | ■ | ■ |
| 0.78 | 1100 | 700 | ■ | — |
| GRADING BUCKETS | | | | |
| 0.59 | 1500 | 440 | ○ | ● |
| 0.72 | 1800 | 510 | ● | ■ |
| 0.80 | 2100 | 570 | ■ | — |
| DITCH CLEANING BUCKETS | | | | |
| 0.86 | 1830 | 630 | ■ | — |

* with bolt-on cutting edge

**Tilt angle 45° L/R Connect to Low-Flow Auxiliary Hydraulic Circuit

- Rated material density up to 2 ton/m³
- Rated material density up to 1.6 ton/m³
- ▲ Rated material density up to 1.4 ton/m³

- Rated material density up to 1.2 ton/m³
- Not applicable

SPECIFICATIONS

CX180E

ENGINE

Model _____ FPT NEF4
 Type _____ Water-cooled, 4-cycle diesel, 4-cylinder in line,
 High pressure common rail system (electric control),
 turbocharger with air cooled intercooler, SCRoF, EGR free.
 Emissions _____ Stage V
 Number of cylinders / Displacement (l) _____ 4 / 4.5
 Bore and stroke (mm) _____ 104 x 132
Rated flywheel horse power
 ISO 9249 (kW) _____ 90.4 at 2200 min⁻¹ (rpm)
 ISO 14396 (kW) _____ 96.5 at 2200 min⁻¹ (rpm)
Maximum torque
 ISO 9249 (Nm) _____ 456 at 1600 min⁻¹ (rpm)
 ISO 14396 (Nm) _____ 470 at 1600 min⁻¹ (rpm)

HYDRAULIC SYSTEM

Main pumps _____ 2 variable displacement axial piston pumps
 with regulating system
 Max. oil flow (l/min) _____ 2 x 159 at 2200 min⁻¹
Working circuit pressure
 Boom/Arm/Bucket (MPa) _____ 34.3 - 36.3
 with auto power boost
 Swing circuit (MPa) _____ 27.9
 Travel circuit (MPa) _____ 34.3
 Pilot pump _____ 1 gear pump
 Max. oil flow (l/min) _____ 22
 Working circuit pressure (MPa) _____ 3.9
Boom cylinders
 Bore (mm) _____ 115
 Stroke (mm) _____ 1179
Arm cylinder
 Bore (mm) _____ 125
 Stroke (mm) _____ 1280
Bucket cylinder
 Bore (mm) _____ 105
 Stroke (mm) _____ 985

SWING

Swing motor _____ Fixed displacement axial piston motor
 Maximum swing speed (min⁻¹) _____ 11.8
 Swing torque (Nm) _____ 45,100

FILTERS

Suction filter (µm) _____ 105
 Return filter (µm) _____ 6
 Pilot line filter (µm) _____ 8

ELECTRICAL SYSTEM

Voltage (V) _____ 24
 Alternator (Amp) _____ 50
 Starter (V - kW) _____ 24 - 4.0
 Battery _____ 2 X 12 V - 72 Ah/5HR

UNDERCARRIAGE

Travel motor _____ Variable displacement axial piston motor
Travel speeds
 High travel speed (Automatic travel speed shifting) (km/h) _____ 4.3
 Low travel speed (km/h) _____ 2.6
 Drawbar pull (kN) _____ 190
 Number of carrier rollers (each side) _____ 2
 Number of track rollers (each side) _____ 7
 Number of shoes (each side) _____ 46

NOISE (PRELIMINARY)

External guaranteed sound level
 (EU Directive 2000/14/EC) _____ LwA 100 dB(A)
 Operator cab sound pressure level (ISO 6396) _____ LpA 69 dB(A)

CIRCUIT AND COMPONENT CAPACITIES

Fuel tank (l) _____ 300
 Hydraulic system (l) _____ 170
 Hydraulic tank (l) _____ 82
 AdBlue tank (l) _____ 60

| PERFORMANCE DATA | | Arm 2.62 m | Arm 3.05 m |
|------------------------|----|------------|------------|
| Boom length | mm | 5150 | 5150 |
| Bucket radius | mm | 1350 | 1350 |
| Bucket wrist action | ° | 178 | 178 |
| A Maximum reach at GRP | mm | 8870 | 9210 |
| B Maximum reach | mm | 9040 | 9380 |
| C Max. digging depth | mm | 6040 | 6470 |
| D Max. digging height | mm | 9250 | 9300 |
| E Max. dumping height | mm | 6630 | 6710 |
| F Min. swing radius | mm | 2990 | 3050 |

| DIGGING FORCE (ISO 6015) | | Arm 2.62 m | Arm 3.05 m |
|--------------------------|----|------------|------------|
| Arm digging force | kN | 79 | 72 |
| with Auto power up | kN | 84 | 77 |
| Bucket digging force | kN | 112 | 112 |
| with Auto power up | kN | 118 | 118 |

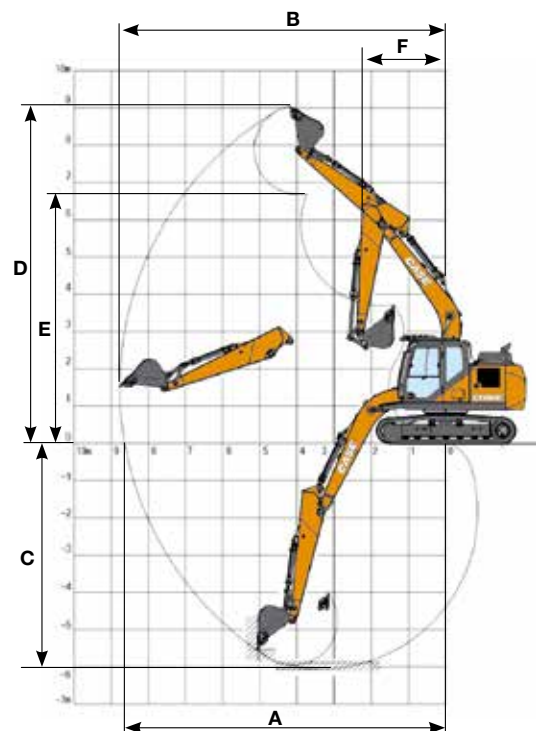

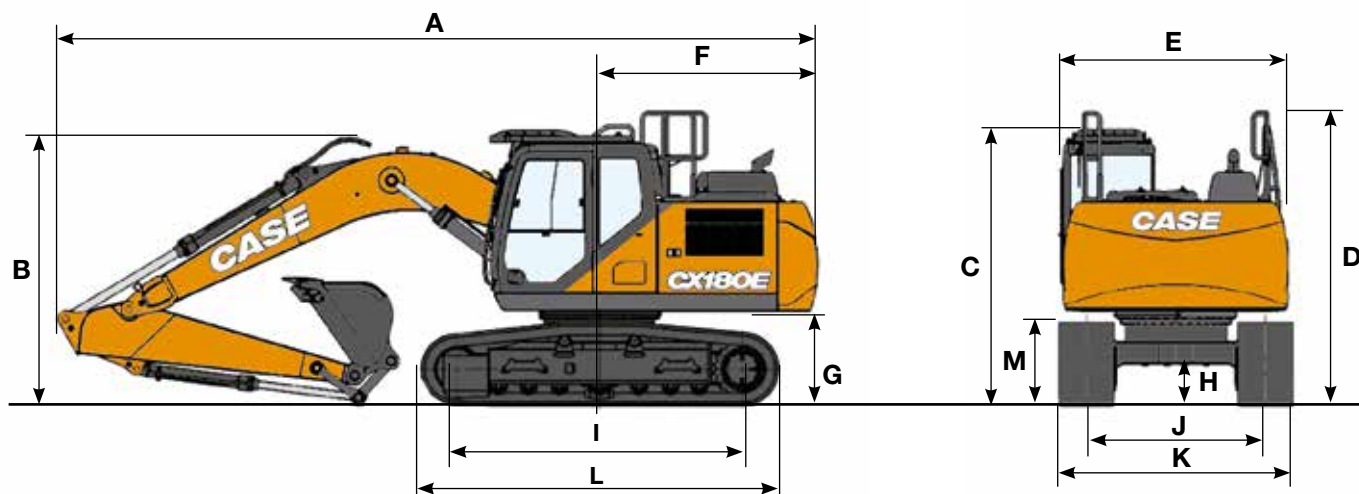

| GENERAL DIMENSIONS | | Arm 2.62 m | Arm 3.05 m |
|---|----|------------|------------|
| Overall length (without attachment) | mm | 4580 | 4580 |
| A Overall length (with attachment) | mm | 8510 | 8570 |
| B Overall height (to top of boom) | mm | 2960 | 3130 |
| C Cab height | mm | 3070 | 3070 |
| D Overall height (to top of handrail) | mm | 3150 | 3150 |
| E Upper structure overall width | mm | 2520 | 2520 |
| F Swing (rear end radius) | mm | 2520 | 2520 |
| G Clearance height under upper structure | mm | 1040 | 1040 |
| H Minimum ground clearance | mm | 440 | 440 |
| I Wheel base (center to center of wheels) | mm | 3370 | 3370 |
| J Track gauge | mm | 2200 | 2200 |
| K Undercarriage overall width (with 600 mm shoes) | mm | 2800 | 2800 |
| L Crawler overall length | mm | 4180 | 4180 |
| M Crawler tracks height | mm | 920 | 920 |

WEIGHT AND GROUND PRESSURE

With 2.62 m arm, 0.68 m³ bucket , 600 mm grouser shoes, operator, lubricant, coolant, full fuel tank and FOPS protection level 2.

| | WEIGHT | GROUND PRESSURE |
|----|----------|-----------------|
| LC | 18400 kg | 0.041 MPa |

Counterweight: 3120 kg

LIFTING CAPACITY

CX180E

| REACH | | | | | | | | | |
|---------------|---|--------|-------|-------|-------|-------|--------------|-------|------|
| Front Side | 2.0 m | | 4.0 m | | 6.0 m | | At max reach | | m |
| | Standard arm 2.62 m, 600 mm shoes, max reach 7.69 m | | | | | | | | |
| 6.0 m | | | | | 3940* | 3940* | 2660* | 2660* | 6.38 |
| 4.0 m | | | 6110* | 6110* | 5080* | 3930 | 2530* | 2530* | 7.35 |
| 2.0 m | | | 8910* | 6600 | 5630 | 3710 | 2650* | 2580 | 7.69 |
| 0 m | | | 10290 | 6180 | 5420 | 3520 | 3020* | 2610 | 7.48 |
| -2.0 m | 8140* | 8140* | 10210 | 6110 | 5360 | 3470 | 3940* | 3020 | 6.69 |
| -4.0 m | 13620* | 13620* | 8020* | 6300 | | | 5960* | 4580 | 5.03 |

| REACH | | | | | | | | | | | |
|---------------|---|--------|--------|------|-------|-------|-------|------|--------------|-------|------|
| Front Side | 2.0 m | | 4.0 m | | 6.0 m | | 8.0 m | | At max reach | | m |
| | Long arm 3.05 m, 600 mm shoes, max reach 8.03 m | | | | | | | | | | |
| 8.0 m | | | | | | | | | 2820* | 2820* | 4.96 |
| 6.0 m | | | | | 3860* | 3860* | | | 2380* | 2380* | 6.79 |
| 4.0 m | | | | | 4690* | 3960 | | | 2310* | 2310* | 7.70 |
| 2.0 m | | | 8260* | 6680 | 5640 | 3710 | 2580* | 2410 | 2440* | 2400 | 8.03 |
| 0 m | | | 10200* | 6170 | 5400 | 3500 | | | 2790* | 2420 | 7.83 |
| -2.0 m | 7690* | 7690* | 10120 | 6030 | 5300 | 3410 | | | 3620* | 2750 | 7.08 |
| -4.0 m | 14190* | 14190* | 8720* | 6160 | | | | | 5890* | 3910 | 5.54 |

* The above loads (kg) are compliant to the ISO standards and refer to the excavator equipped without bucket. The indicated loads are no more than 87% of hydraulic system lift capacity or 75% of static tipping load. Values marked with an asterisk (*) are limited by the hydraulic lifting capacity.

HAMMER

CX180E

Direct Fit

| Model | Install Weight kg | Reference machine settings | | Arm 2.62 m | Arm 3.05 m |
|-------------------|----------------------|----------------------------|------------------------|---------------|---------------|
| | | Flow l/min | Relief Pressure Mpa | | |
| CB BREAKER | | | | | |
| CB240S | 1100 | 95 | 19-21 | □ | — |

- Applicable
- Not applicable

BUCKETS

CX180E

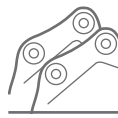

CX180E - Direct Mount

| Capacity m ³ (ISO7451 HEAPED) | Width mm | Weight kg | Arm 2.62 m | Arm 3.05 m |
|---|-------------|--------------|---------------|---------------|
| GENERAL PURPOSE BUCKETS | | | | |
| 0.24 | 450 | 350 | ○ | ○ |
| 0.36 | 600 | 390 | ○ | ○ |
| 0.50 | 750 | 440 | ○ | ○ |
| 0.62 | 900 | 480 | ○ | ○ |
| 0.70 | 1000 | 500 | ○ | ○ |
| 0.78 | 1100 | 540 | ○ | ● |
| 0.87 | 1200 | 570 | ● | ▲ |
| 1.00 | 1350 | 630 | ▲ | ■ |
| HEAVY DUTY BUCKETS | | | | |
| 0.26 | 450 | 420 | ○ | ○ |
| 0.38 | 600 | 480 | ○ | ○ |
| 0.51 | 750 | 550 | ○ | ○ |
| 0.65 | 900 | 620 | ○ | ○ |
| 0.70 | 1000 | 660 | ○ | ○ |
| 0.75 | 1050 | 680 | ○ | ● |
| 0.78 | 1100 | 700 | ○ | ● |
| 0.91 | 1200 | 740 | ● | ▲ |
| 1.00 | 1300 | 800 | ▲ | ■ |
| GRADING BUCKETS | | | | |
| 0.59 | 1500 | 440 | ○ | ○ |
| 0.72 | 1800 | 510 | ○ | ○ |
| 0.85 | 2100 | 570 | ○ | ● |
| DITCH CLEANING BUCKETS | | | | |
| 0.86 | 1830 | 630 | ○ | ● |
| 90° TILT DITCH CLEANING BUCKETS** | | | | |
| 0.46 | 1500 | 650 | ○ | ○ |
| 0.55 | 1800 | 700 | ○ | ○ |
| 0.61 | 2000 | 740 | ○ | ● |
| 0.68 | 2200 | 810 | ● | ■ |
| 0.74 | 2400 | 840 | ■ | — |



CX180E - Quick coupled

| Capacity m ³ (ISO7451 HEAPED) | Width mm | Weight kg | Arm 2.62 m | Arm 3.05 m |
|---|-------------|--------------|---------------|---------------|
| GENERAL PURPOSE BUCKETS | | | | |
| 0.24 | 450 | 350 | ○ | ○ |
| 0.36 | 600 | 390 | ○ | ○ |
| 0.50 | 750 | 440 | ○ | ○ |
| 0.62 | 900 | 480 | ○ | ○ |
| 0.70 | 1000 | 500 | ○ | ● |
| 0.78 | 1100 | 540 | ● | ▲ |
| 0.87 | 1200 | 570 | ▲ | ■ |
| 1.00 | 1350 | 630 | ■ | — |
| HEAVY DUTY BUCKETS | | | | |
| 0.26 | 450 | 420 | ○ | ○ |
| 0.38 | 600 | 480 | ○ | ○ |
| 0.51 | 750 | 550 | ○ | ○ |
| 0.65 | 900 | 620 | ○ | ○ |
| 0.70 | 1000 | 660 | ○ | ● |
| 0.75 | 1050 | 680 | ● | ● |
| 0.78 | 1100 | 700 | ● | ■ |
| 0.91 | 1200 | 740 | ■ | — |
| GRADING BUCKETS | | | | |
| 0.59 | 1500 | 440 | ○ | ○ |
| 0.72 | 1800 | 510 | ○ | ● |
| 0.80 | 2100 | 570 | ● | ● |
| DITCH CLEANING BUCKETS | | | | |
| 0.86 | 1830 | 630 | ● | ▲ |

* with bolt-on cutting edge

**Tilt angle 45° L/R Connect to Low-Flow Auxiliary Hydraulic Circuit

- Rated material density up to 2 ton/m³
- Rated material density up to 1.6 ton/m³
- ▲ Rated material density up to 1.4 ton/m³

- Rated material density up to 1.2 ton/m³
- Not applicable

BUILDING A STRONG CASE.

Since 1842, at CASE Construction Equipment we have lived by an unwavering commitment to build practical, intuitive solutions that deliver both efficiency and productivity.

We continually strive to make it easier for our customers to implement emerging technologies and new compliance mandates.

Today, our global scale combined with our local expertise enables us to keep customers' real-world challenges at the center of our product development.

The vast CASE dealers' network is always ready to support and protect your investment and exceed your expectations, while also providing you with the ultimate ownership experience.

Our goal is to build both stronger machines-and stronger communities. At the end of the day, we do what's right for our customers and our communities so that they can count on CASE.

CNH Industrial
Deutschland GmbH
Case Baumaschinen
Benzstr. 1-3 - D-74076 Heilbronn
DEUTSCHLAND

CNH Industrial
Maquinaria Spain, S.A.
Avenida Aragón 402
28022 Madrid - ESPAÑA

CNH Industrial France, S.A.
16-18 Rue des Rochettes
91150 Morigny-Champigny
FRANCE

CNH Industrial Italia Spa
Lungo Stura Lazio 19
10156, Torino
ITALIA

CASE Construction Equipment
Cranes Farm Rd
Basildon - SS14 3AD
UNITED KINGDOM

NOTE: Standard and optional fittings can vary according to the demands and specific regulations of each country. The illustrations may include optional rather than standard fittings - consult your Case dealer. Furthermore, CNH Industrial reserves the right to modify machine specifications without incurring any obligation relating to such changes.

Conforms to directive 2006/42/EC

CASECE.COM
00800-2273-7373

The call is free from a land line.
Check in advance with your Mobile Operator if you will be charged. Toll free number not available from all calling areas.

